

FREEMOTION
Powered By **iFT™**

INTERACTIVE. PERSONAL. TRAINING.

27 SERIES

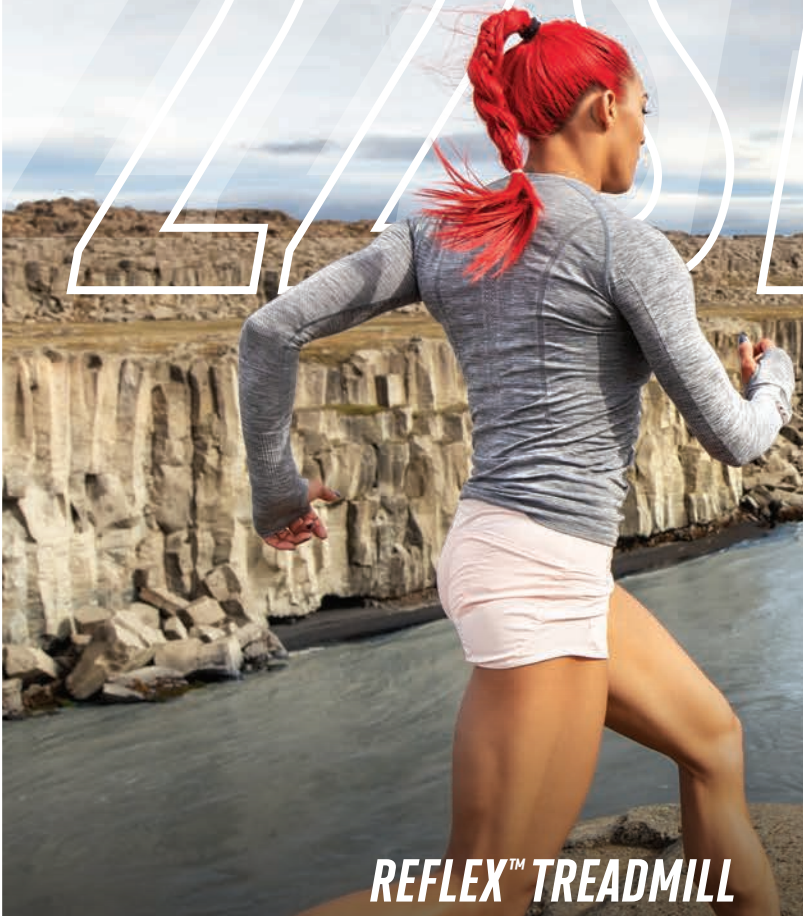

HANNAH EDEN - ICELAND

REFLEX™ TREADMILL

INCLINE TRAINER



ELLIPTICAL



RECUMBENT BIKE



UPRIGHT BIKE



COACHBIKE™



CONTENT

WORKOUT LIBRARY // PG 3

FITNESS COACHES // PG 4

GLOBAL WORKOUTS // PG 5

STUDIO CLASSES // PG 6

GOOGLE MAPS™ // PG 7

TECHNOLOGY // PG 8

PRODUCT BENEFITS // PG 10

PRODUCT FEATURES // PG 11

SPECIFICATIONS // PG 12

POWER REQUIREMENTS // PG 13

WARRANTIES // PG 14

t22.9 REFLEX™ TREADMILL

THE CARDIO EXPERIENCE REIMAGINED

Exclusively on content-driven cardio machines from Freemotion, your members can explore the world through thousands of coach-led workouts, right from the cardio floor. Powered by iFit, the 22 SERIES keeps users engaged with vivid imagery, motivational coaching, and auto-adjusting technology that delivers an immersive and interactive cardio experience.

Deliver the best-in-class cardio experience with the REFLEX™ Treadmill, the preferred treadmill of boutique studios around the world. Its proprietary cushioning deck reduces impact and enables a longer, stronger, and healthier run.





THOUSANDS OF COACH-LED
WORKOUTS

Access an expansive library of on-demand workouts led by expert fitness coaches from around the world. Search or sort by location, trainer, exercise type, workout duration, intensity, and more!

WORLD-RENOWNED

FITNESS COACHES

We've hand-selected 100+ Olympic champions, celebrity trainers, physical therapists, marathoners, and location guides to be your iFit coaches. With unique training styles and personalities that motivate and inspire, you'll quickly find your new favorite trainer.



INTERACTIVE. PERSONAL. TRAINING.

GLOBAL WORKOUTS

Explore the world without leaving the room with thousands of inspiring training videos beautifully filmed in stunning locations around the globe, including 40+ countries and all 7 continents. Your machine's incline will even adjust to match the terrain and instructions of your coach.



BETINA GOZO — ANTARCTICA



Travel the World

Virtually travel to unique locations with guides that share facts, information, and history that transform your workout into an engaging and educational experience.



Workout in Breathtaking Locations

Discover the Pyramids of Egypt, hike the Scottish Highlands, or take a stroll through Florence with an exciting and immersive fitness experience.



Participate in Iconic Races

Challenge yourself by virtually participating in iconic races like the Boston Marathon right from the cardio floor.

INTERACTIVE. PERSONAL. TRAINING.

STUDIO CLASSES

Experience the hype of a high-intensity studio class alongside other participants and taught by fitness instructors that motivate and inspire you to finish strong. Let your coach guide you through the workout and virtually control your machine.



Gideon Akande

A LITTLE BIT OF EVERYTHING



Betina Gozo

TOTAL-BODY INTERVAL RUN



Anja Garcia

LADDER INTERVALS AND...



EIFFEL TOWER - PARIS, FRANCE

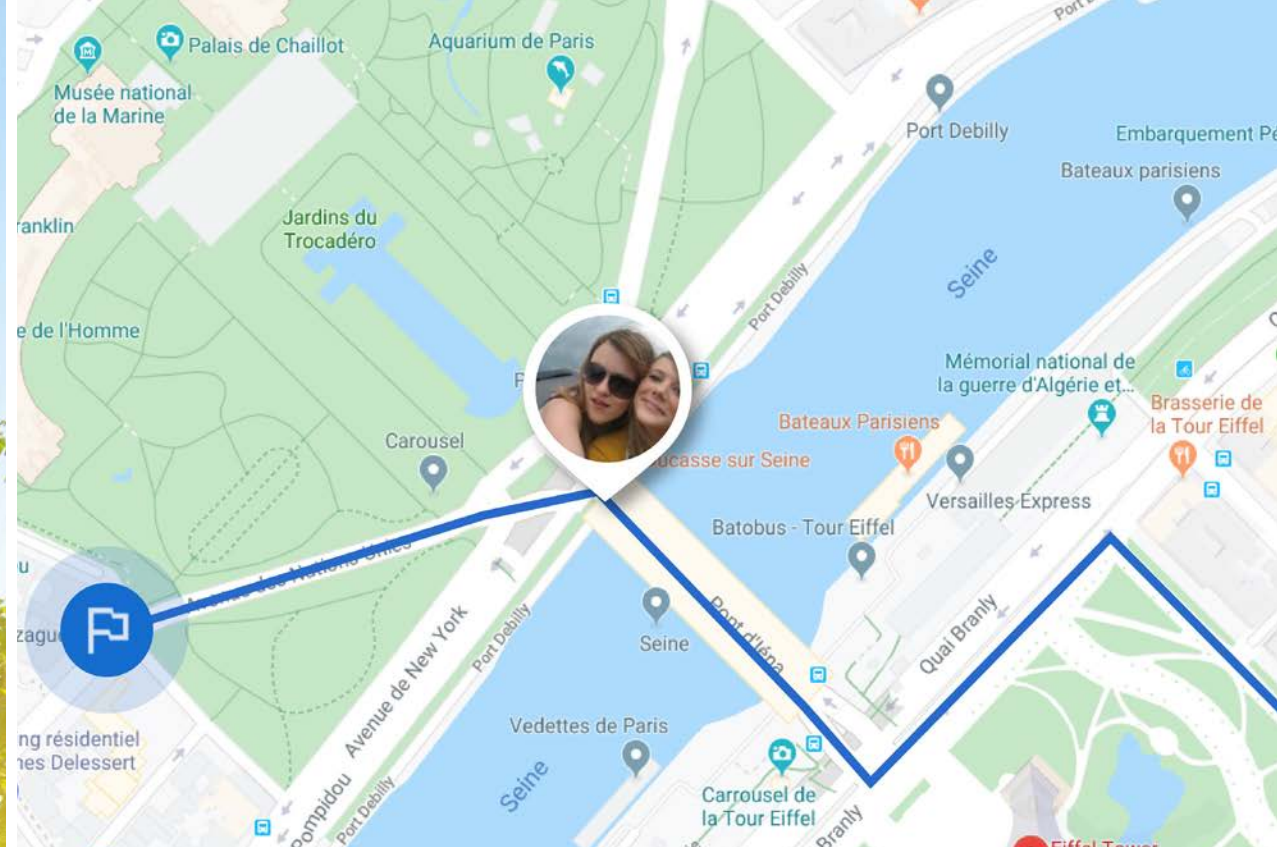

INTERACTIVE. PERSONAL. TRAINING.

GOOGLE MAPS

Run anywhere in the world with Google Maps. Create a route, and iFit will adjust your treadmill's incline to match the on-screen terrain, allowing you to virtually explore 10 million miles (16 million km) of mapped locations. Revisit your childhood neighborhood or train for an out-of-town race (5K, marathon, etc.) before completing it in person.

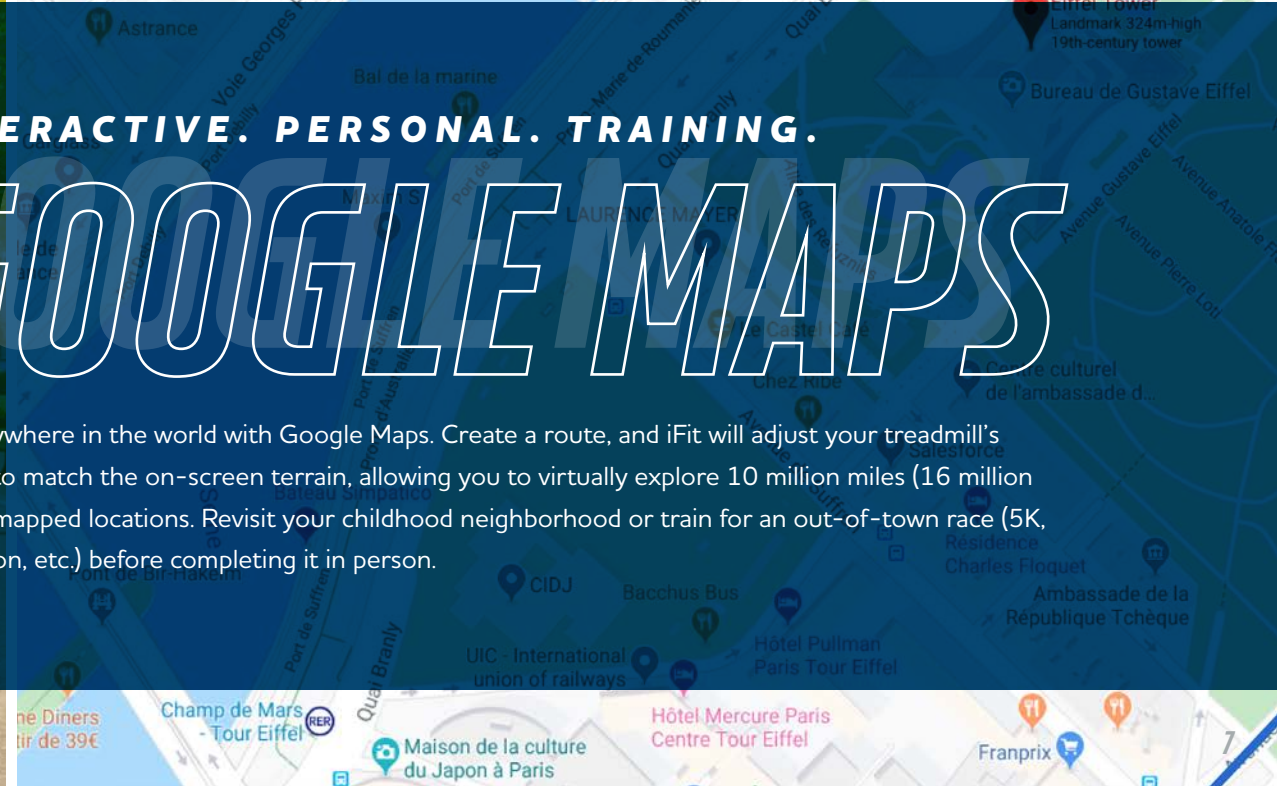

I'M GOING TO
INCREASE YOUR SPEED!

AUTO-ADJUSTING

TECHNOLOGY

Each interactive workout allows your coach to remotely adjust the incline or speed of your treadmill to mirror the on-screen content, creating an immersive and engaging training experience.



CARMEL RODRIGUEZ — FLORENCE, ITALY

CONTENT ON-DEMAND, 24/7

Get access to your favorite fitness coach on your schedule, whenever you choose to workout.

ADVANCED WORKOUT METRICS

Never lose sight of your personal fitness goals with real-time metrics that go beyond traditional feedback, leveraging heart rate, intensity, incline statistics, and more to measure and track your fitness journey.

PROGRESSIVE WORKOUTS

Complete a full workout series that continuously challenges with each new workout.

EVER-EXPANDING CONTENT LIBRARY

With an extensive and ever-growing library of engaging on-screen content, you'll always have a new workout to experience or a unique location to explore.

PRODUCT

BENEFITS



t22.9 REFLEX™ TREADMILL



29% greater reduction in impact force
20.5% greater reduction in tibial shock
*Compared to the competition**

A SAFER, HEALTHIER RUNNING EXPERIENCE

Easier on hips, knees, and ankles, the REFLEX™ proprietary cushioning deck absorbs shock to help run longer and stronger. Providing a 52% greater reduction in tibial shock compared to flat surface running,* **the REFLEX Deck is the longevity solution for walking or running.**

*Based on a Freemotion commissioned university study comparing impact of running on a Freemotion REFLEX™ series treadmill, a Life Fitness 95TS, a Precor TRM 835, and flat surfaces.

PRODUCT

FEATURES

KNOW YOUR ZONE

Get real-time data during your workout with built-in EKG grips, so you know when you're in the ideal heart-healthy zone. Also compatible with ANT+ and Polar®.

SHIFT GEARS QUICKLY

Quickly achieve your desired speed by pressing two 1-STEP™ Controls back-to-back – for example, pressing '2' and '5' will adjust the speed to 2.5 mph (4 km/h) allowing you to quickly reach your ideal speed.

POWER UP

Charge your devices during your workout with a convenient USB port.

HIIT-FRIENDLY CARDIO

Quickly adjust your speed and incline with the convenient 1-STEP™ Controls, great for HIIT sessions.

t22.9 REFLEX™ TREADMILL



HIGH-DEFINITION DISPLAY

Immerse yourself in visually stunning imagery while working out in exotic locations around the globe, or watch a favorite TV program on this high-definition 22-in (55 cm) capacitive touchscreen.

A COOL WORKOUT

Stay cool throughout the workout with a conveniently-located adjustable 3-speed fan, or select the AutoBreeze™ function to enjoy a variable flow that responds to your pace.



PRODUCT

SPECIFICATIONS

MODEL # FMTL70920

Display Type	22 in (55 cm) HD Capacitive Touchscreen Built-in TV Tuner* (Available Soon)
Workouts	Thousands of Coach-Led, Unlimited with Google Maps
Featured Languages	EN, also DE, ES, FR, IT, PT, RU, ZH
Entertainment	HDMI, MPEG-2, MPEG-4 US & Canada: H.264 (AVC) International: H.265 (HEVC)
Audio Connections	Bluetooth, 3.5 mm headphone jack
Connectivity	Ethernet or Wifi minimum: 10 Mbps per unit (Dedicated Ethernet recommended)
Elevation System	0% to +15% incline
Speed Range	0-15 mph (0-24 km/h)
Drive Motor	AC 5.0 CHP Commercial
Deck	Two-Sided REFLEX™ Deck
Running Surface/Belt	Double Layered Quiet Belt 21.5 x 60 in (54.6 x 152 cm)
AutoBreeze™ Fan	Adjustable, 3-Speed, 8-in (20.3 cm) CrossFlow™ Fan
Heart Rate Monitoring	EKG Pulse Sensors, ANT+ and Polar Compatible
Accessories Holder(s)	Phone/Accessories Tray, Bottle Holder
Step-Up Height	12 in (30.5 cm)
Maximum User Weight	400 lbs (181 kg)
Product Weight	619 lbs (280.7 kg)
Shipping Weight	649 lbs (294.4 kg)
Shipping Dimensions (L x W x H)	89 x 41 x 30 in (226 x 104 x 76 cm)
Certifications	cTUVus, FCC/IC, BQB

*NTSC, PAL, SECAM etc.

PRODUCT OPTIONS

Units	Metric Imperial
Power	120 VAC, 20 Amp 240 VAC, 15 Amp
Color	Black White Red Yellow

For the full list of specifications, visit freemotionfitness.com

22 SERIES

t22.9 REFLEX™ TREADMILL

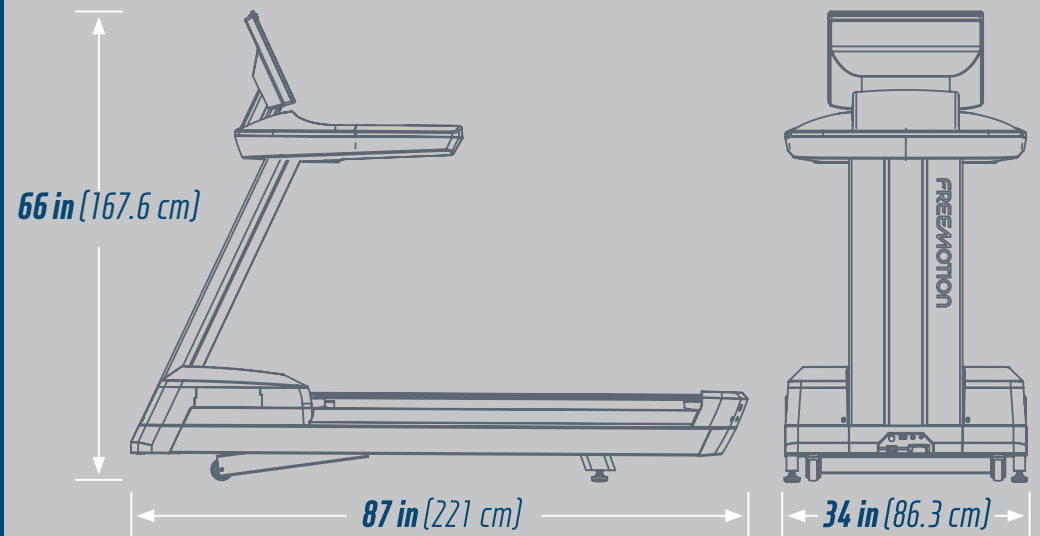

NETWORK CONNECTIVITY

Freemotion requires a minimum of Category 5e (Cat5e) twisted pair ethernet cable. Freemotion recommends Category 6 (Cat6) twisted pair ethernet cable to ensure stable and efficient connection.

Freemotion requires all switching devices to be capable of handling up to 10/100/1000 Mbps, and a dedicated network connection for each connected fitness product. All connected products, whether on WiFi or via Ethernet, should be on a secure and protected network capable of providing a minimum bandwidth of 10 Mbps per unit.

TREADMILL

POWER PROVISION

WARNING:

Failure to follow may cause unexpected behavior of the treadmill or other machine malfunctions.



110-Volt Treadmill Applications

Freemotion treadmills require an individual branch circuit using a NEMA 5-20R Isolated Ground Receptacle. The hot, neutral, and ground wires must each be independently isolated (not looped or tied to other circuits).



220-Volt Treadmill Applications

Freemotion treadmills require an individual branch circuit using an NEMA 6-20R Receptacle. Two hot and the one ground wires must be independently isolated (not looped or tied to other circuits).

ELECTRICAL REQUIREMENTS NOTICE

Electrical Applications

- » Do not modify the plug provided with this product. If it will not fit your electrical outlet, have a proper outlet installed by a qualified electrician.
- » Electrical supply may fluctuate in your area. To ensure stable performance if the product we require the following wiring gauges based on the distance between the single treadmill and the panel: 100' = 10 Gauge, 150' = 8 Gauge, 200' = 6 Gauge.

When designing a facility or installing new Freemotion equipment into a facility, it is important to have the correct electrical power provisions in order for the equipment to operate safely and properly. Each treadmill must be furnished with an Individual Branch Circuit. Circuits for 100-Volt models must include a 20-amp circuit breaker and individual 20-amp isolated ground receptacles for each treadmill. Circuits for 220-Volt must include a 15-amp circuit breaker and individual 15-amp isolated ground receptacles for each treadmill. The NEC requires that each outlet have dedicated conductors of at least 12 AWG for line, neutral and ground for 20-amp service. Larger conductors (10 AWG) may be required for long branch circuits or high temperatures to prevent voltage drop. Dedicated outlets must not share line, neutral or ground conductors with other outlets. This means that a single breaker, one hot wire, one neutral wire, and one ground wire are connected from the panel to a single electrical load, in this case, 1 treadmill.

ALL CIRCUITS FOR TREADMILLS SHOULD NOT SHARE A NEUTRAL GROUND. Each neutral wire and each ground wire should be tied back to the panel directly. This should help to avoid 3 problems commonly experienced:

- » **Overloading the Circuit Breaker** – With only one treadmill connected to a single circuit breaker in the electrical panel, the smaller circuit breaker in the treadmill will trip first if there is an over-current situation due to abnormal treadmill operation. If more than one treadmill is wired to the same panel breaker, the additional current requirements may frequently overload and trip the panel breaker, even though the treadmills are operating normally.
- » **Overloading the Neutral Wire** – If there are multiple treadmills connected to the same neutral wire, even if each hot conductor is wired to separate breakers, there is a risk of overloading the neutral wire, possibly resulting in a dangerous situation (could overheat and cause a fire) and/or more commonly, low voltage at the outlet. As a result of the low voltage the amperage (AMPS) goes up to keep up with the current demand. With the high amounts of current comes high heat, which will damage the electrical components such as the power board, console, and other small components within the treadmill.
- » **Low Voltage at the Outlet** – A few things can cause this; the most common is too many treadmills on one circuit (or neutral wire), which overloads the wire, heating it up, and causes the voltage at the outlet to drop. This can also happen if the wires are not a large enough size, or if the distance from the panel to the outlet is too far. Low voltage at the outlet can only be measured when the load is at its peak. The voltage may be fine when all the treads are off, but lower significantly when they are all on and drawing 20-amps. Low voltage causes problems for the drive motor, power board, and the motor controller, and can result in unexpected behaviors of the treadmill.
- » **The benefits of an Isolated Ground (IG)** – The primary reason for the use of an IG is to provide a noise-free (electromagnetic interference) ground return, separate from the equipment grounding return. The IG provides an isolated separate ground path for the ground reference in the treadmill. The IG also helps eliminate the potential for a "ground loop", which can cause electromagnetic interference.

CARDIO: HIGH-USAGE - 22, 10, & 8 SERIES	US & CANADA	INTERNATIONAL
Frame (not including coatings), Drive Motor	7 Years	7 Years
Parts and Console	2 Years	2 Years
Labor	1 Year	1 Year
Cosmetic & Wear Items*	6 Months	6 Months
CARDIO: LOW-USAGE - 22, 10, & 8 SERIES**	US & CANADA	INTERNATIONAL
Frame (not including coatings), Drive Motor	7 Years	7 Years
Parts and Console	3 Years	3 Years
Labor	3 Years	1 Year
Cosmetic & Wear Items*	6 Months	6 Months
TV ATTACHMENTS	US & CANADA	INTERNATIONAL
MYE Digital LCD TV	3 Years	3 Years
MYE TV Controller & Wireless Receiver	2 Years	2 Years
MYE Wireless Transmitter	5 Years	5 Years
INDOOR BIKES	US & CANADA	INTERNATIONAL
Frame (not including coatings)	7 Years	7 Years
Belt	5 Years	5 Years
Parts and Console	2 Years	2 Years
Labor	1 Year	1 Year
Cosmetic & Wear Items*	6 Months	6 Months
FUSION	US & CANADA	INTERNATIONAL
Frame (not including coatings)	10 Years	10 Years
Parts	2 Years	2 Years
Ropes and Labor	1 Year	1 Year
Cosmetic & Wear Items*	6 Months	6 Months
STRENGTH/BENCHES/RIGS/RACKS/ATTACHMENTS	US & CANADA	INTERNATIONAL
Frame (not including coatings)	10 Years	10 Years
Parts	3 Years	3 Years
Cables and Labor	1 Year	1 Year
Cosmetic & Wear Items*	6 Months	6 Months
Upholstery & Padding	120 Days	120 Days
FREE WEIGHTS	US & CANADA	INTERNATIONAL
Urethane-coated Weights (repair or replace at our discretion)	3 Years	3 Years
Rubber-coated Weights (repair or replace at our discretion)	2 Years	2 Years

*Includes Non-warning Decals, Deck Rails, Pulse Grips, USB, Audio Jack, Handrails, Motor Hood, Fan Levers, Water Bottle Holders, Pedals, Pedal Straps, Seats, Handles/Levers/Knobs, Hand Grips, Removable Trays, Weight Pins, Springs, Belts (except Walking Belts), Accessories, Rust on Any Metal Components.

**For non-dues paying facilities with machine usage of 6 hours or less per day.

FREEMOTION.
WARRANTIES

FREEMOTION®

PHONE +1 877-363-8449 || **EMAIL** sales@freemotionfitness.com || **WEBSITE** freemotionfitness.com